



ASSEMBLY INSTRUCTION FOR ACME FURNITURE





MODEL#BD02322

Thank you for purchasing this quality product. Be sure to check all packing material carefully for small parts which may have loose inside the carton during shipment. Separate, identify and count all parts and metal hardware. Compare with all parts list to be sure all parts are present. If any part(s) are missing or damaged, please contact your local furniture dealer. For efficient and speedy service, please indicate the model number and code letter of part(s) needed.

Do not fully tighten screw until fully assembled

COMPONENT PARTS		
DESCRIPTION	PART NAME	Q'TY (PCS)
(A)	SEAT FRAME WITH CUSHION 	1
(B)	LEG 	4

HARDWARE REQUIRED

NO	NAME	PART	QTY
1	Allen key		1pc
2	JCBB M8 x 60mm		8pcs
3	M8 Spring washer		8pcs
4	5/16" Flat washer		8pcs

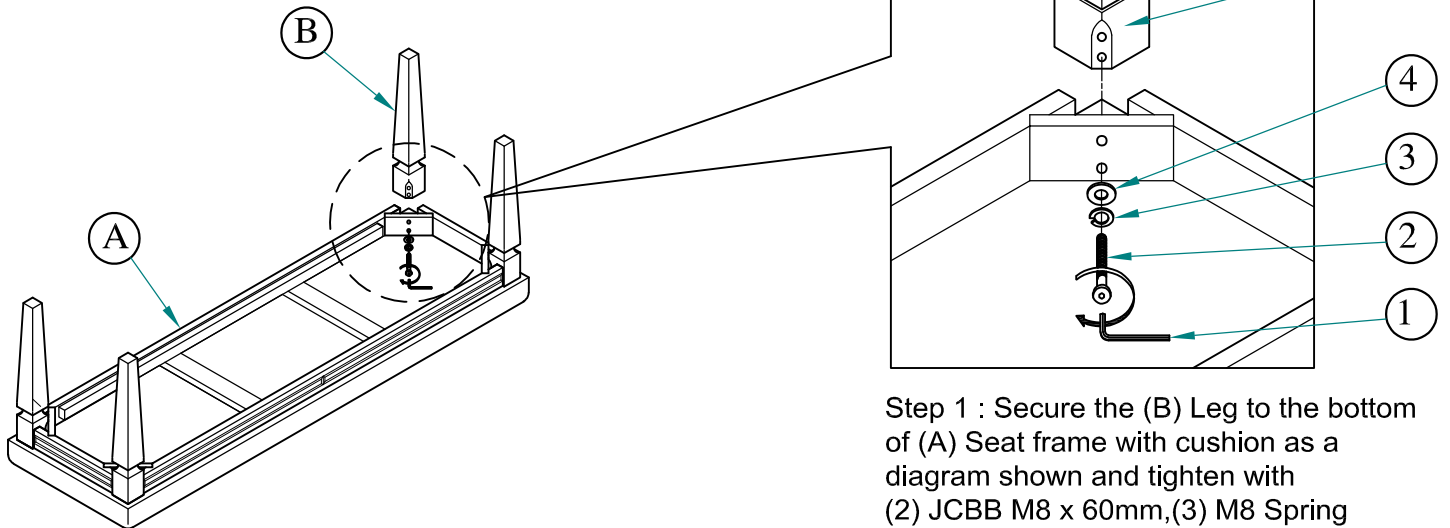

Step 1 : Secure the (B) Leg to the bottom of (A) Seat frame with cushion as a diagram shown and tighten with (2) JCBB M8 x 60mm, (3) M8 Spring Washer & (4) 5/16" Flat Washer.

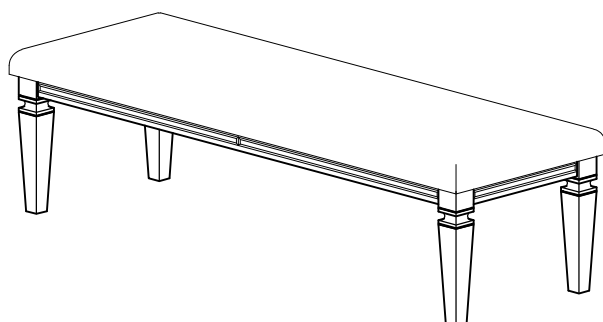

Assembly completed